

PARÇA KODU PART CODE	PARÇA ADI PART NAME	ERKEK TERMİNAL MALE TERMINAL	a ÖLÇÜSÜ (AYAR) a MEASURE (SET)	s ÖLÇÜSÜ (KALINLIK) s MEASURE (THICKNESS)	Malzeme Material	Kaplama / Coating		
						SN	AG	Nİ
TD 2143.80 DP	STANDART DIŞI FİŞ K.A.DÜZ 6.3 (0.80) =DP=	0.80	0.55±0.1	-----	(CuZn30) Pirinç / Brass	-	-	-
TD 2143.80 RP	STANDART DIŞI FİŞ K.A.DÜZ 6.3 (0.80) =RP=	0.80	0.55±0.1	-----	(CuZn30) Pirinç / Brass	-	-	-
TD 2143.80 RPK	STANDART DIŞI FİŞ K.A.DÜZ 6.3 (0.80) =RPK=	0.80	0.55±0.1	-----	(CuZn30) Pirinç / Brass	+	-	-

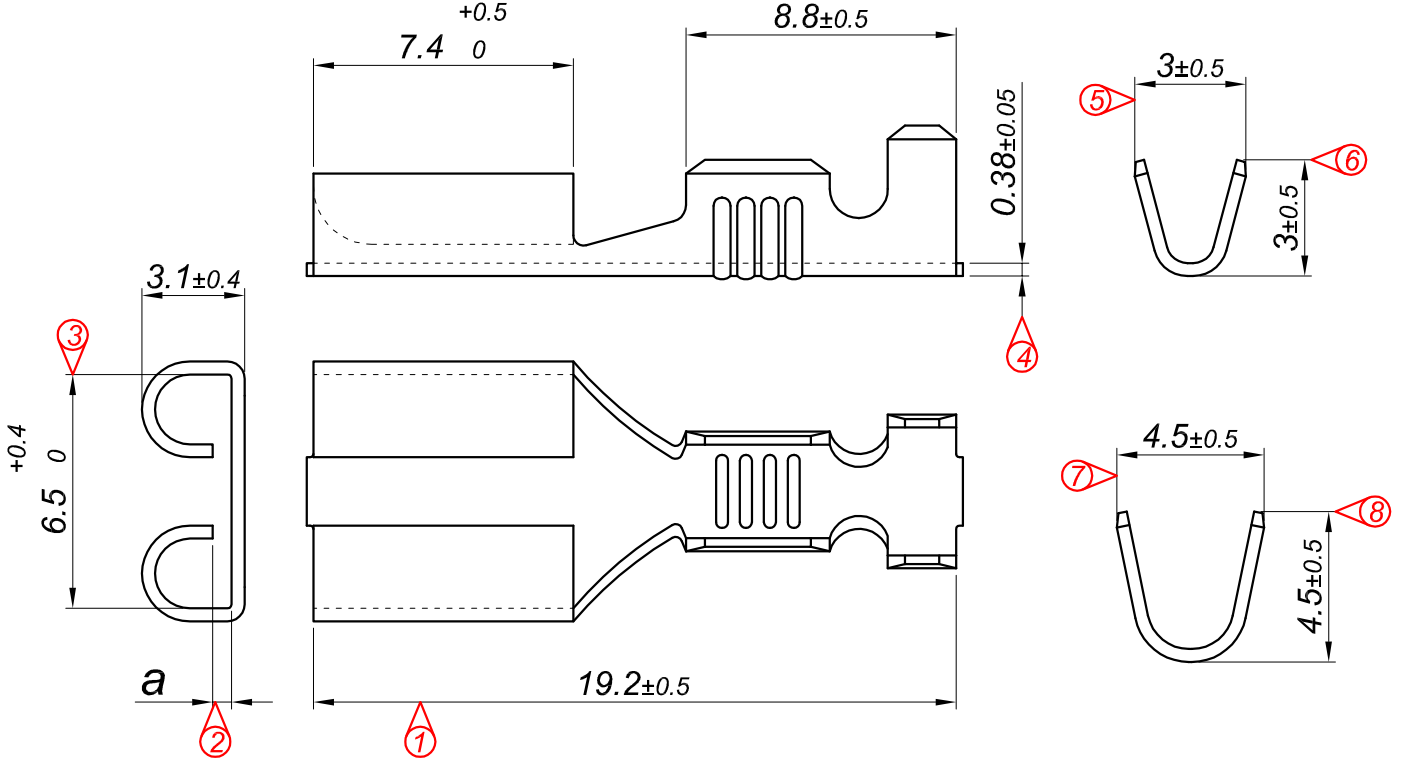

Perspektif  
Perspective

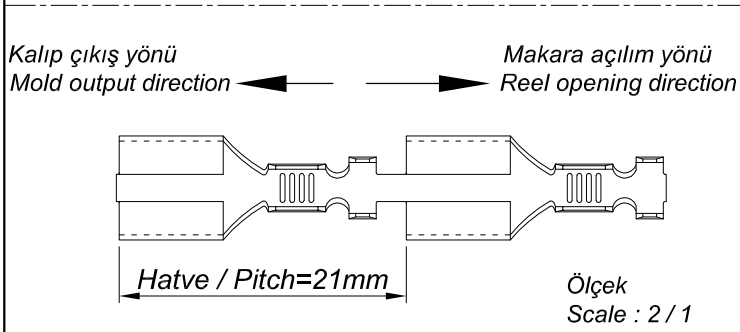
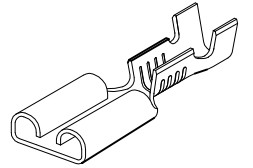

Kablo Kesiti  
Wire Section : 0.50 - 1 mm<sup>2</sup>

Resim üzerinden ölçü almayınız  
do not measure on drawing

Tarih / Date	09.06.2011	İmza /Signature	Ölçek /Scale			
Çizen / Desing	M.Yağcı		5 / 1	No		
Onay / Approval	S.Gölcük				Değişiklik / Revision	Tarih/Date



Parça Adı:  
Part Name

STANDART DIŞI FİŞ  
KÜÇÜK AYAK DÜZ 6.3

Parça Kodu:  
Part Code

TD 2143